



ECO-FRIENDLY, RESISTANT TO NATURAL CONDITIONS

DECKADO is an environmentally-friendly and ecological product produced by using recyclable polymer and hard wood fibers.

Different from wood, Deckado is not Affected by damage caused by pests and insects, it is noteworthy thanks to its antibacterial properties. It is resistant to moisture and humidity. Cracking, disintegration, distortion, flexure do not occur in the product.

PRODUCTS

DECKADO 140 MM CLASSIC

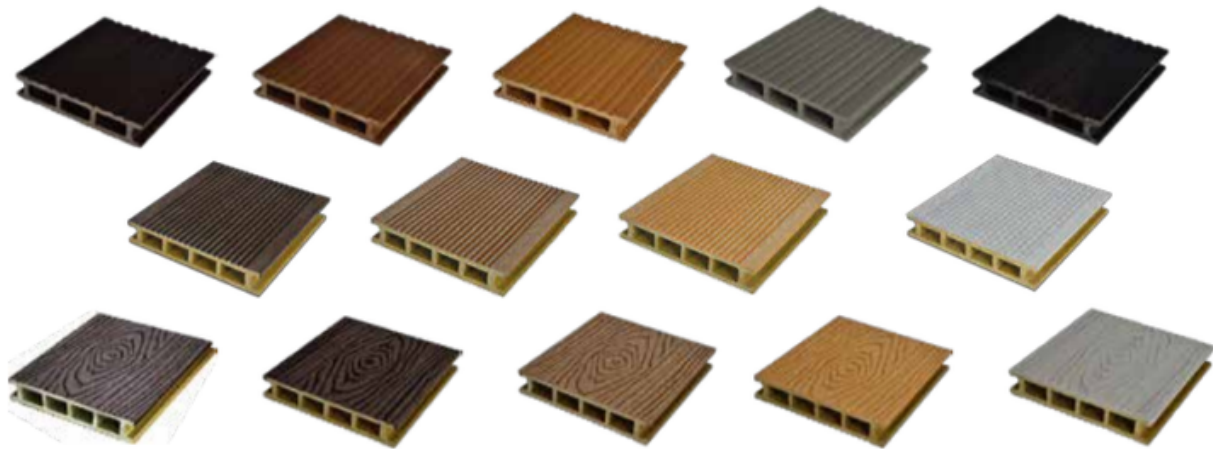

DECKADO 150 MM CLASSIC

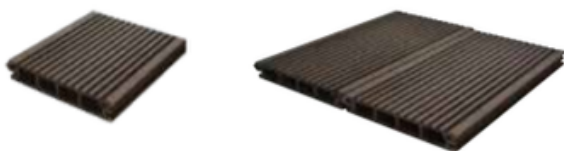

ACCESSORIES



ALUMINIUM F
PROFILE



COMPOSITE
SIDE COVER



30X50 MM BASE
BOARD



EDGE COVER
CAP



METAL CLIPS



60X40 MM L
SIDE COVER



Color fading was minimized by providing maximum resistance to rain, cold, sun and all kinds of weather conditions.

AREAS OF USAGE

- Swimming pools edges
- Beaches
- Piers
- Verandas
- Pergolas
- Camellias
- Conservatories
- Garden paths
- Walking paths in the country
- Open spaces and outdoor areas





APPLICATION EXAMPLES

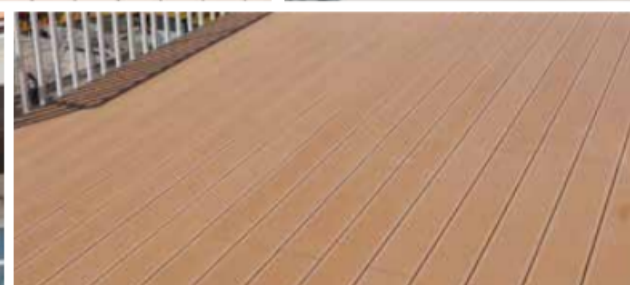
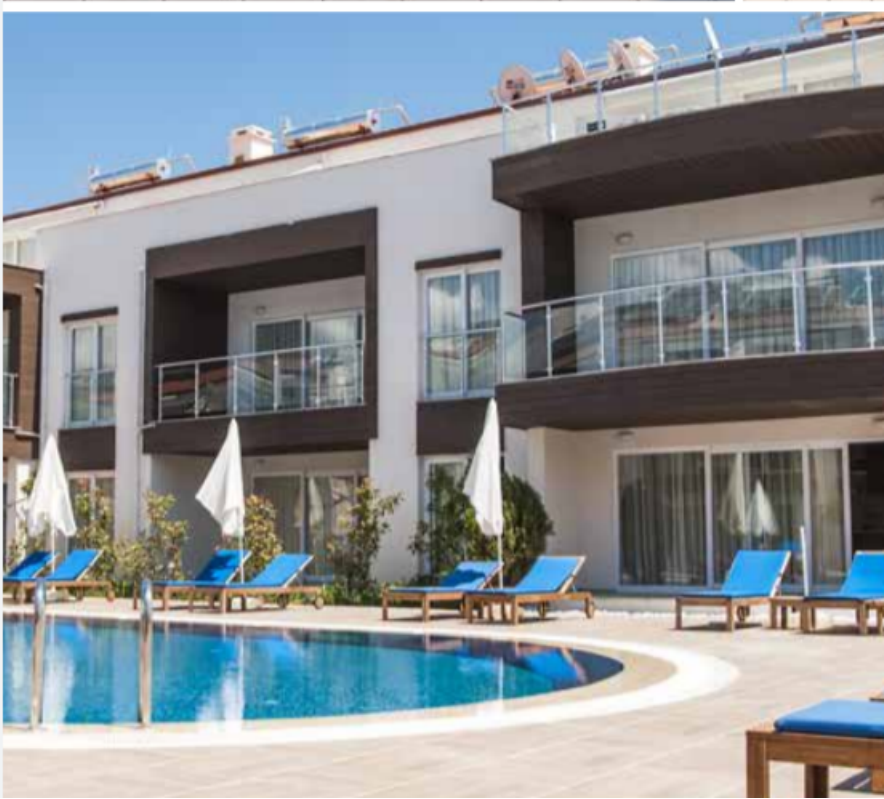

140x26 mm Technical Specifications

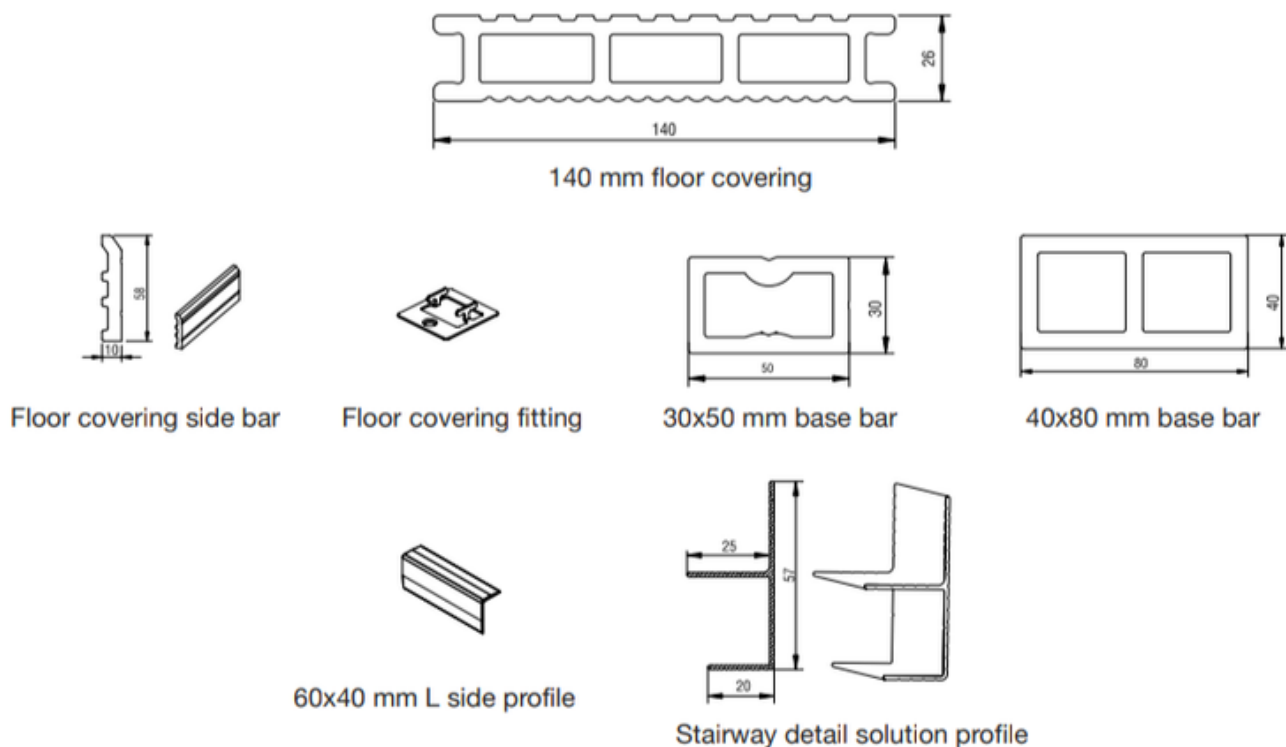

Assembly details

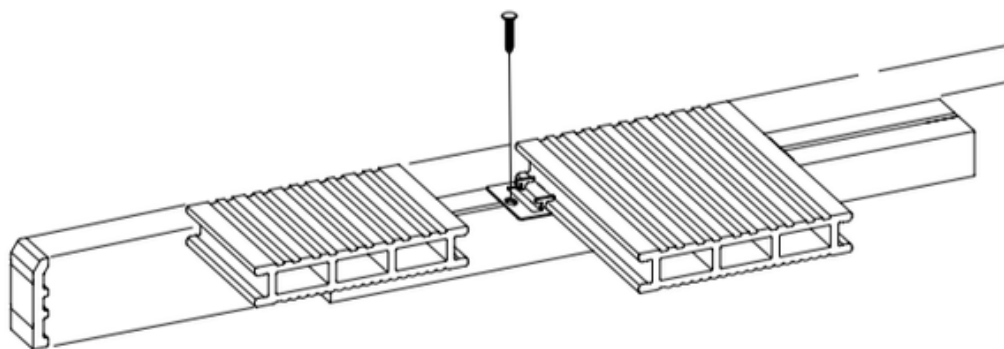

FLOOR COVERING ASSEMBLY

1. 140 mm floor covering
2. 30x50 mm base bar
3. Floor covering side bar
4. Floor covering fitting assembly screw
5. Initial fitting
6. Floor covering fitting

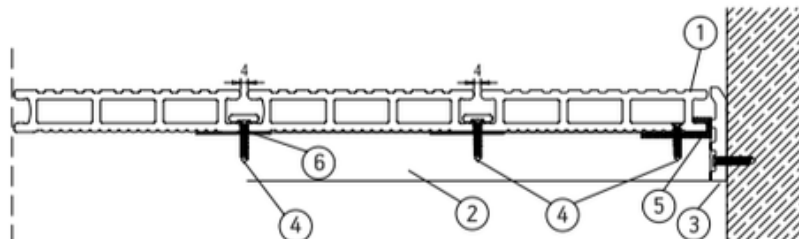

Panel width is 140 x 26 mm. As it is mounted with a joint gap, it is preferred for floor coverings in open areas. It does not cause water and dust accumulation. It is designed with special grooves to prevent slipping. The sides and corners of the applied areas are closed with 58 mm side bars.

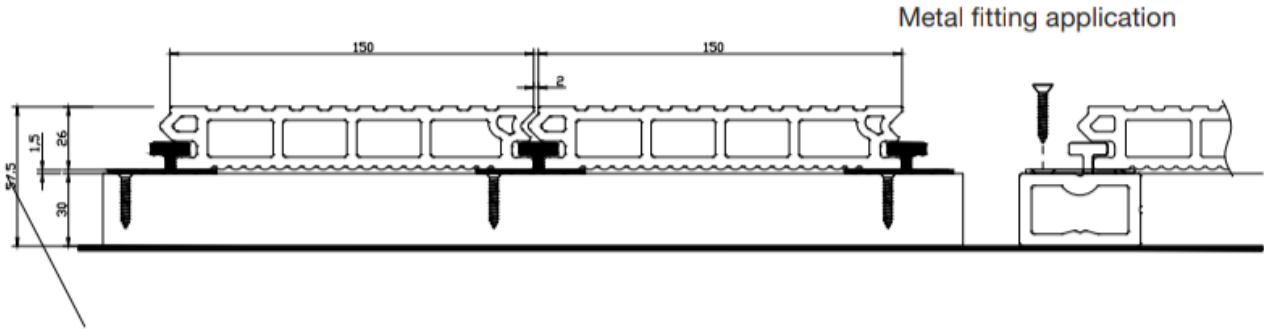
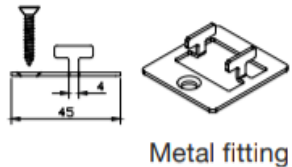
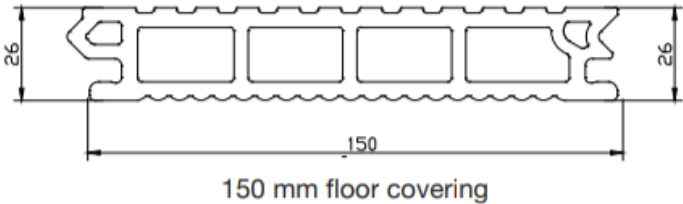

Assembly details

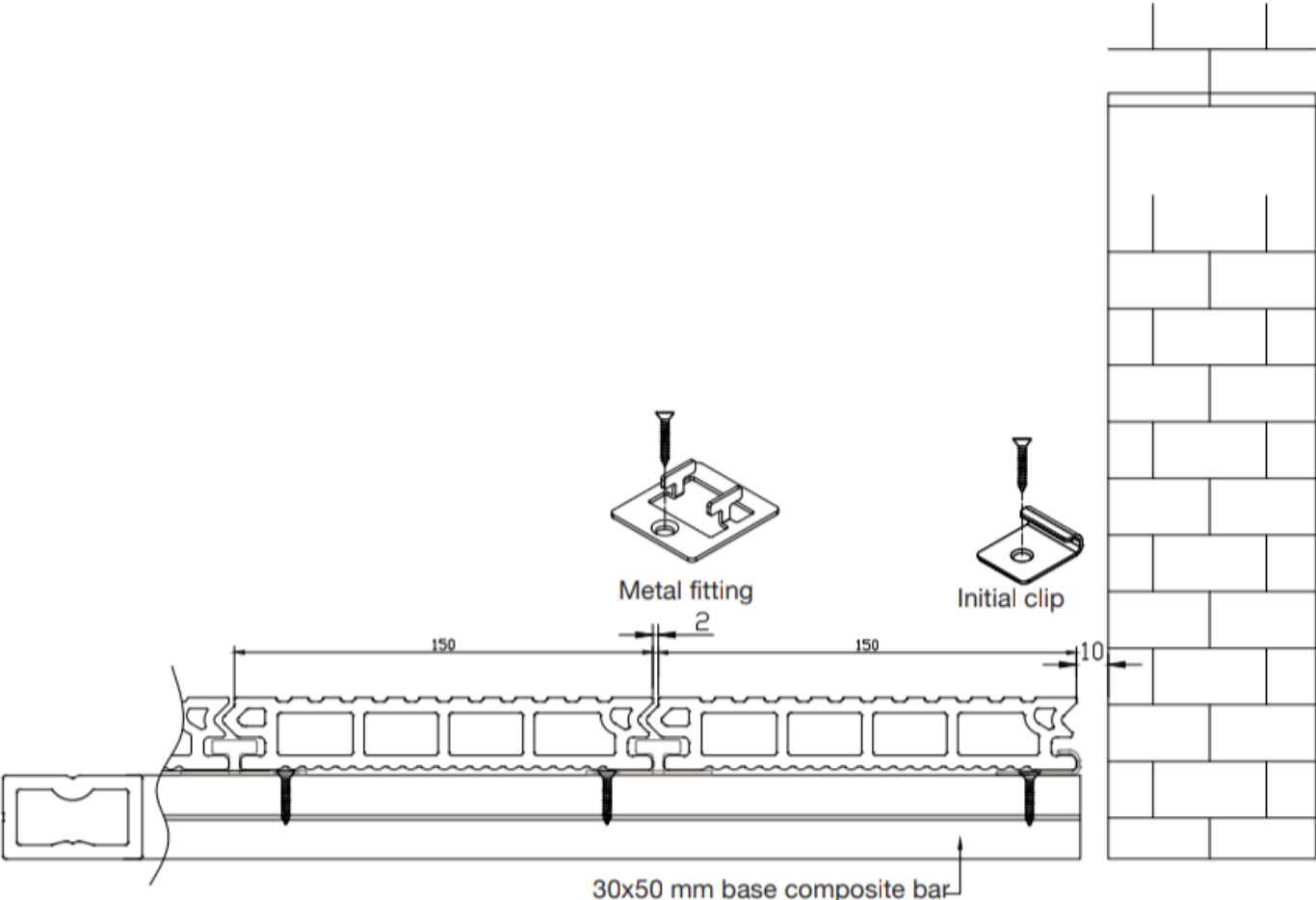

DECKING MOUNTING STAGES

1- Base beads application and distance of dimensions

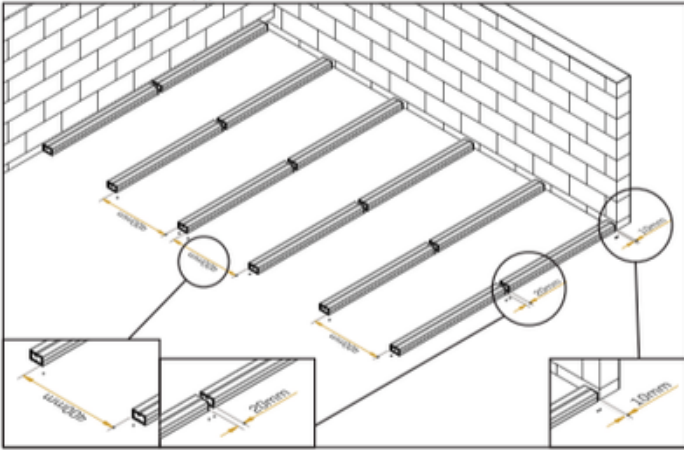

- 30x50 mm sized base beads must be fixed to the ground with proper fixing screws. The distance between the fixing screws must be 50 cm maximum.
- The base beads must be installed with a slope of 4 degrees at the beginning in order to avoid the water puddle on the surface of the deck.
- The base beads must be installed with maximum distance of 40 cm.
- The base beads end joints must be installed with distance of 2 cm to in order to enable the water discharge easily.
- The base beads must be installed with a distance of 1 cm at the wall beginnings.

2- Decking wall side or empty side initiation pattern:

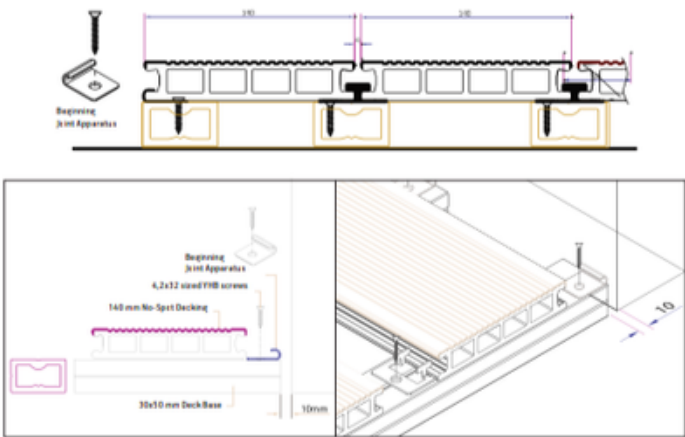

- After the base beads are installed decking beginning joint apparatus and 3,9x32 sized YHB screws must be used to screw the apparatus. As shown in the figure.

- After the beginning joint apparatus are installed decking must be placed to the apparatus channels.

3- Metal or plastic floor decking joint apparatus installation:

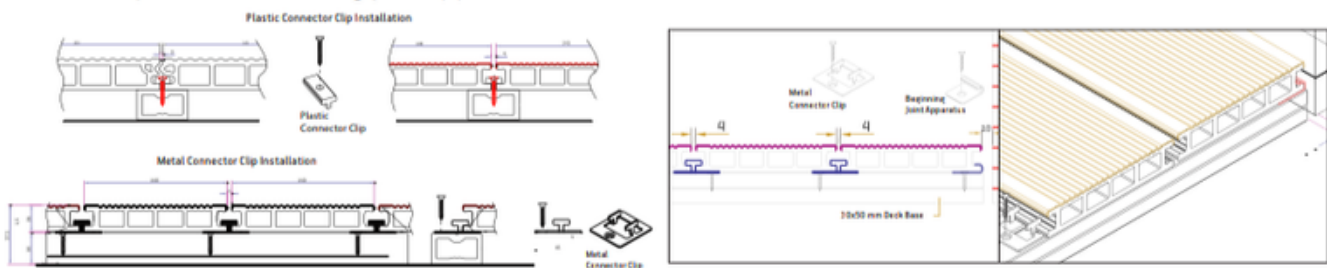

- Metal or plastic T shaped joint apparatus are fixed to the bottom surface beads by screws. Nails are not absolutely used and screws are not applied to the Decking.

4- The dimensions between base beads and upper decking in front head installation of decks

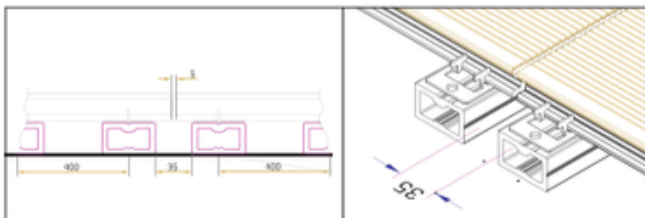

- The distance between base beads decking connection spots must be 3.5 cm space and they must be fixed to the ground and 5 mm distance must be left between the two decking edge connections.

5- 60x40mm composite side cover profile and decking front head cover installation

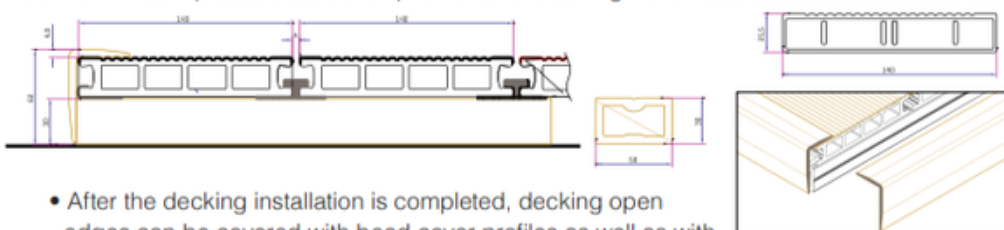

- After the decking installation is completed, decking open edges can be covered with bead cover profiles as well as with 60x40 mm composite profiles or aluminum F profiles.

DECKADO TEST RESULTS / PVC-WOOD FIBER

Test Name	Standart No	Test Method		Catalogue Values
Test Name	ISO 1183-1	Method A		1,40 kg/m ³
Vicat Softening Temperature	ISO 306	Method B50		89,8 °C
		23 °C	1 kg /1,5 m	15 J
		(-10 °C)	1 kg /1,5 m	15 J
Water Absorption	EN 317	24 Hour	Thickness % Weight %	0,34 0,55
Termal Prolongatino	EN 479	100 °C 1 Hour		% 0,10
Bending Endurance	EN 310			36,40 N/mm ²
Bending Elasticity Module	EN 310			6468 N/mm ²
Aging Test	EN 513			250-4000 Hour color values



ISO 14001:2004



ISO 9001:2000



TSE CERTIFICATE



SERVICE COMPLIANCE
CERTIFICATE